

M&J VALVE

AN SPX BRAND

4-Way Diverter Valve



SPX[®]

A Diverter Valve System by Flow Measurement and Valve Specialists

Now there's a high quality 4-way diverter valve system specifically designed for the rigid requirements of bi-directional meter proving. The M&J 4-Way Diverter Valve is the heart of this system. Its unique design and operating characteristics allows our valve to be cycled hundreds of times per day. A special team of valve engineers and designers with cumulative experience of almost 200 years worked with M&J's flow measurement engineers and specialists to produce the 4-Way Diverter Valve. This team is thoroughly familiar with meter proving requirements as they and other M&J Valves personnel have designed, tested and started up some of the world's largest, most sophisticated metering systems over the past decade.

The M&J 4-Way Diverter Valve and its operating mechanism (manual, electric motor or hydraulic actuator) are designed to operate as a system ideally suited for meter proving, which requires:

Frequent operation (cycling). A diverter valve often is cycled 300 times per day compared to once per week for ordinary valves and only twice per year for many valves.

Rapid operation. In bi-directional meter proving the diverter valve must cycle in 4 to 10 seconds compared to the 30 to 60 seconds cycling time for ordinary valves.

No Leakage. Proof of no leakage during each prover run is required by the API Liquid Measurement Manual 2531. The 4-Way Diverter Valve with its automatic pressure seating method indicates the seal condition every time the valve seats. On automated systems, prover runs are canceled if the seal condition is not acceptable.

Figures 1 and 3 show the decrease in body pressure in the seated position as compared to the unseated or cycling position (Fig. 2).

The pressure drops as the valve is being seated because the downward movement of the tapered plug and the compression of the resilient seals create a net volume increase in the body cavity. This automatic decrease in body pressure is called "SID" or Self Induced Differential.

Low differential sealing. The diverter valve must show sealing proof at low differential pressures (2-5 psi) compared to the high differential pressures (40-400 psi) across normal valve seats. Average (normal) valves require the higher pressures to "set" or "energize" their seats, but this helpful seating force is not available in bi-directional prover systems.

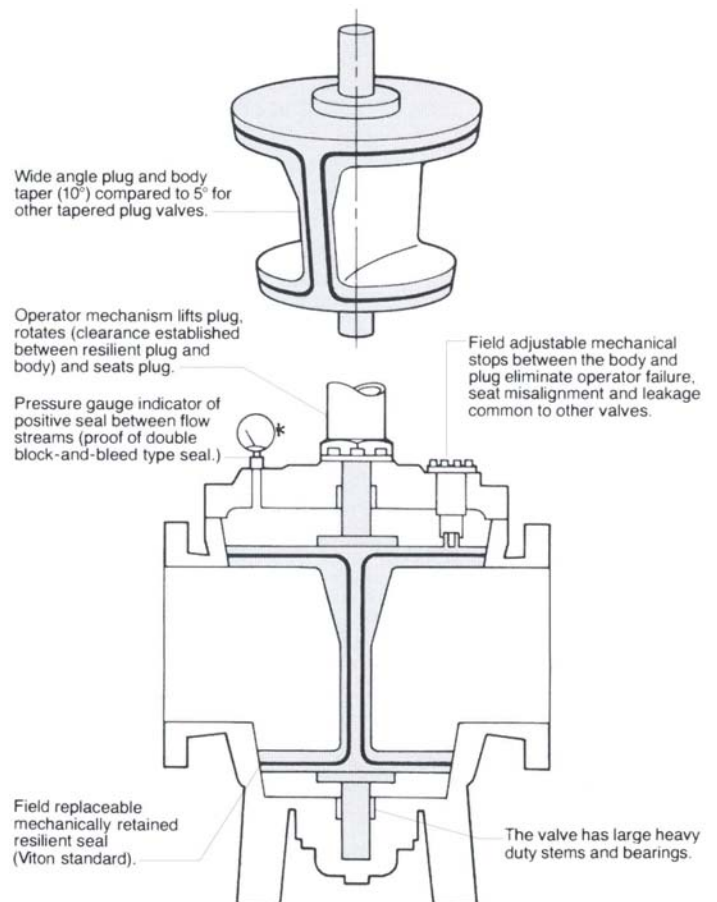
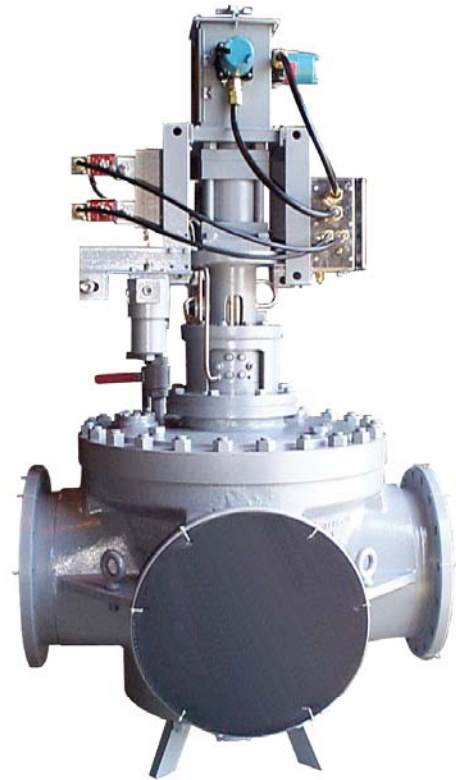

Diverter Valve Cycle in Bi-Directional Prover

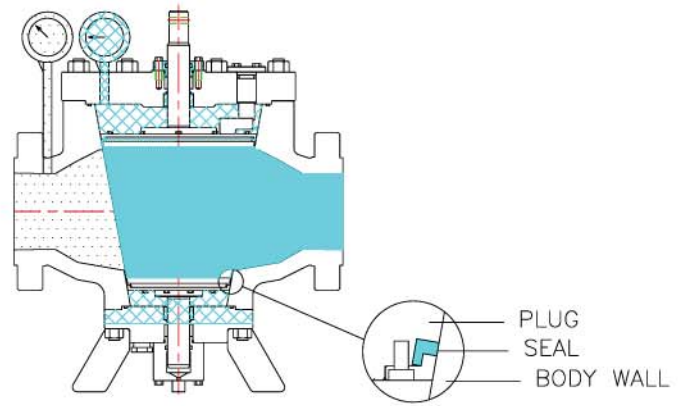
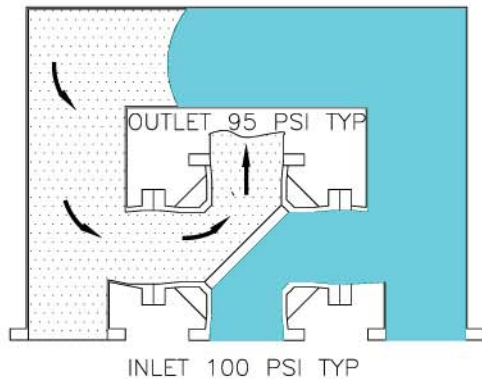

VALVE SEATED IN RIGHT POSITION: PRESSURE GAUGE AUTOMATICALLY INDICATES REDUCED BODY PRESSURE WHICH PROVES TIGHT SHUT-OFF AND POSITIVE SEPARATION OF FLOW STREAMS.

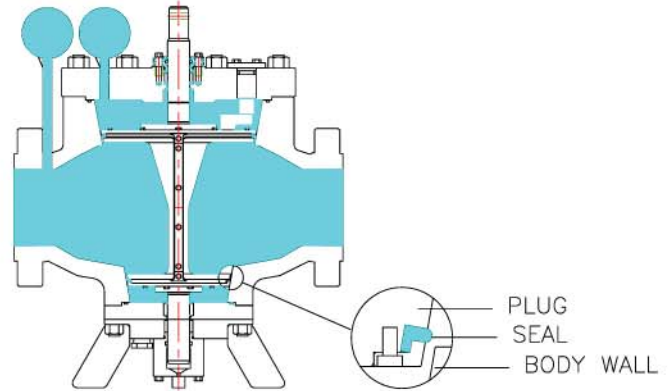
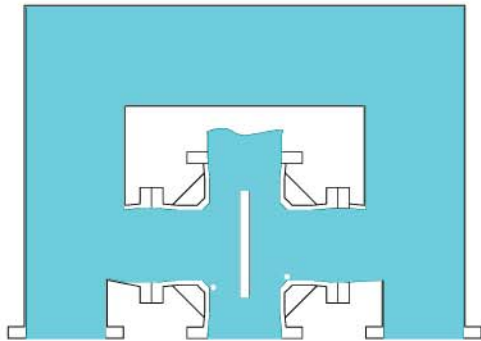

VALVE UNSEATED: PLUG IS RAISED TO EFFECT CLEARANCE BETWEEN RESILIENT SEALS AND BODY SEATS. PLUG TURNS AND HALFWAY THROUGH CYCLE FLOW PASSES DIRECTLY THROUGH VALVE (FROM INLET TO OUTLET PORT) WITH VERY LITTLE RESTRICTION.

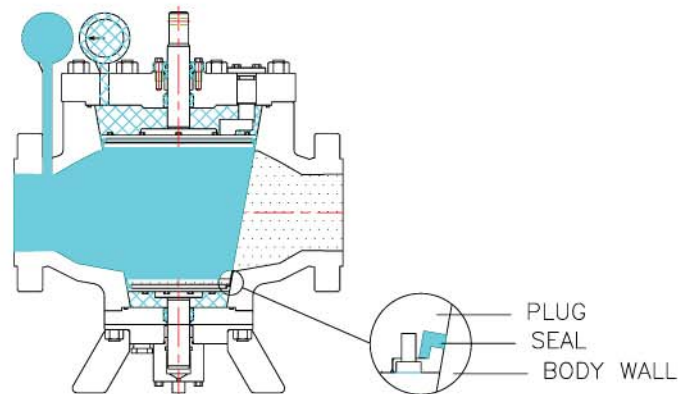
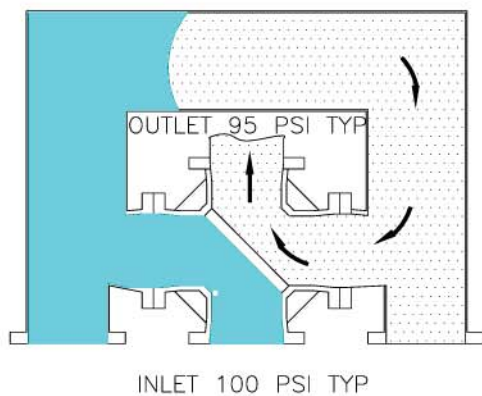

VALVE SEATED IN LEFT POSITION: PLUG HAS BEEN LOWERED, SEALS COMPRESSED AND REDUCED BODY PRESSURE AGAIN INDICATES SEAL INTEGRITY, SEPARATION OF FLOW STREAMS AT LOWER DIFFERENTIAL PRESSURE.

S. I. D. - Differential Pressure Gauge Assembly

The widely accepted "Pressure Gauge Seating Method" for proof of "Double Block and Bleed Type Seal" has been simplified with the use of the Differential Pressure Gauge. All M&J 4-way Valves are supplied with a 0-50 psi differential pressure gauge. The differential check relief valve assembly is set to hold a 25 psi lower pressure in the body than the prover or valve port. The 25 psi differential is indicated on the 0-50 psi differential pressure gauge which is very easy to read. The one-half scale and very sensitive differential pressure gauge is much easier to read than a 1,000 psi pressure gauge which would be used for a 300 series valve. The Differential Pressure Gauge Seating Method is simple, automatic, without solenoids, etc.; and a differential pressure switch for remote indication can be easily installed.

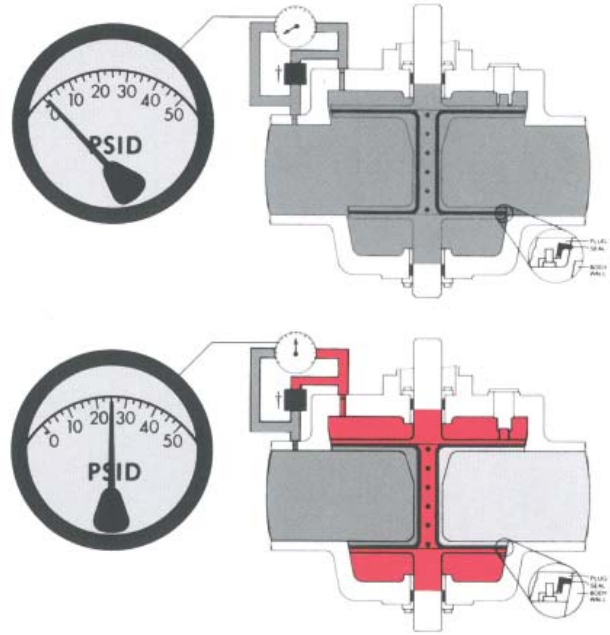

Low Pressure Loss

Sizes	3"	4"	6"	8"	10"	12"	16"	20"	24"*
Cv Values	400	647	1550	2425	4250	5100	8800	14,000	19,000

Face to Face Dimensions

Sizes	3"	4"	6"	8"	10"	12"	16"	20"	24"*
ANSI 300	17"	17"	24"	24"	32"	32"	48"	58"	58"
ANSI 600	18"	18"	26"	26"	36"	36"	48"	62"	62"
ANSI 900	11 3/4"	13 1/2"	-	-	-	-	-	-	-

SPX®

FLOW CONTROL

Your local contact:



SPX Flow Control
 19191 Hempstead Hwy
 Houston, TX 77065
 Phone: (800) 231-3690 Fax: (281) 894-1332
 E-mail: mjvalve@spx.com

For more information about our worldwide locations, approvals, certifications, and local representatives, please visit www.mandjvalve.com.

SPX Corporation reserves the right to incorporate our latest design and material changes without notice or obligation.

Design features, materials of construction and dimensional data, as described in this bulletin, are provided for your information only and should not be relied upon unless confirmed in writing.