

M&J VALVE

AN SPX BRAND

Installation, Operation & Maintenance Manual Expanding Gate Valve



M&J VALVE

AN SPX BRAND

M&J Valve
19191 Hempstead Highway
Houston, TX 77065

Telephone: 281-469-0550, Outside Texas (800) 231-3690

Fax: 281-894-1332

E-Mail: mjvalve@spx.com

Web Site: www.mandjvalve.com

SPX reserves the right to incorporate our latest design and material changes without notice or obligation. Design features, materials of construction and dimensional data, as described in this bulletin, are provided for your information only and should not be relied upon unless confirmed in writing.

Table of Contents

General Information.....	5
Installation	5
Unpacking.....	5
Handling.....	5
Installation.....	5
Features	6
Closure Mechanism	6
Seats.....	6
Stems/Seals.....	6
Body/Bonnet	7
Handwheel Operation	7
Actuation.....	7
Pressure Relief Valve.....	7
Operation.....	8
Normal Operation.....	8
Block and Bleed Procedure	8
Emergency Seat Sealant Injection.....	9
Body Flushing and Draining.....	9
Emergency Stem Seal Plastic Packing Injection	10
Replacing the Injectible Packing	11
Maintenance	11
Stem Bearings	11
Stem.....	11
Yoke Tube	11
Major Overhaul	11
Exploded View and Parts List	12-13

M&J Valve Expanding Gate Valve Installation, Operation & Maintenance Manual

I. General Information

1. The M&J Valve Model EG valves are cast full bore through conduit valves with rising stem and parallel expanding gate and segment for tight mechanical seal and positive shut-off, both upstream and downstream, and under both low and high differential pressure. This design has proven performance in critical applications all over the world, such as isolation valves in power plants, ESD valves in production, block valves in process systems, high temperature valves in refineries, and pipeline valves in critical areas. The mechanical seal is not affected by line surges or vibration.
2. Valves are designed, manufactured, and tested in accordance with API-6D unless otherwise specified. End to end dimensions will conform to API-6D. Flanged end valve flanges are in accordance with ANSI B16.5 (24" and smaller) and MSS SP-44 (larger than 24").
3. Carbon steel weld end valves have weld end connections which are readily field weldable. End preparations match specified mating pipe bores. Transition pieces are provided when specified.
4. Located on the body of the Expanding Gate Valve, the nameplate (Figure 1) provides applicable information including size, pressure class, materials, seals, pressure/temperature ratings and serial number. Reference to the serial number will expedite any request regarding your valve. Note: The serial number is also stamped on the body near the bonnet joint.

M&J VALVE									
HOUSTON, TEXAS									
SIZE	CLASS	MODEL	API	F/F					
BODY	GATE	SEAT	STEM	SEAL					
TEMP								CHARPY TEMP	
MOP									
DATE MFG		LICENSE NO						SERIAL NUMBER	

Figure 1

II. Installation

1. Unpacking

1.1 All valves should be inspected on receipt for lost components or damage.

1.2 Remove end connection protectors and thoroughly inspect interior of valve and end connections for damage or foreign material.

1.3 All valves are shipped in the closed position to protect sealing surfaces.

1.4 Install loose items such as stem protectors, handwheels, etc. if separate from valve assembly.

2. Handling

2.1 Handling equipment appropriate for the valve weight is required.

2.2 The valve may be lifted by slings or end flanges.

3. Installation

Install the valve in the open position with the preferred pressure side upstream. The preferred pressure side is the right hand flange when looking at the lettered and fitting side of the body. This flange is painted red and has "pressure side" stamped on the flange O.D.

- 3.1 Orient valve in piping to provide clearance and allow access to the operator.
- 3.2 Flanged end valves should be installed using the appropriate gasket (not supplied) and conventional flange installation procedures.
- 3.3 Weld end valves should be installed using qualified welders and weld procedures appropriate for the mating materials. Valve should be welded in the open position.

3.4 Prior to operating the valve from the open position, the piping should be thoroughly flushed to prevent foreign matter from damaging sealing surfaces.

3.5 After installation and system testing, the valve should be drained to remove test fluid. (See IV, 4.2.)

III. Features

The Expanding Gate Valve is the result of many years of experience with gate valves of all types. The Expanding Gate Valve is a full bore valve with parallel expanding gate and segment for positive shut-off and minimal head loss. The Expanding Gate Valve incorporates a number of advanced features of proven reliability, and in addition, is designed for ease of maintenance.

1. Closure Mechanism

The valve is equipped with an expanding gate and segment assembly for positive closure. A full operating cycle is defined as movement of the gate from one position (i.e., fully open) to the opposite position (i.e., fully closed), and then back to the original position. When moving to either the fully open or fully closed position, the segment stops and the gate continues along the machined angle forcing the gate and segment apart and into positive contact with the seats, thus ensuring a positive seal.

2. Seats

The valve is equipped with removable seats which are fitted into the valve body. At high pressure, with the gate and segment wedged apart, the seal ring will deform elastically and the contact load of the gate or the segment will be carried by the metal seat.

In addition to the fit in the body, the seats have a non-metallic sediment guard between the seat and the valve body. Each seat (6" bore and up) is also equipped with a groove and passages which allow grease or sealant to be injected between the seat and the gate/segment. This allows for lubrication of the seat and the gate/segment or, in the case of damage or wear, sealant may be injected to provide an emergency seal until repairs can be made.

3. Stem/Seals

The forged head of the stem fits into a slot in the gate. The upper end of the stem is threaded for operation. A cover or cap protects the stem threads from the elements or from accidental damage. A sealed rod attached to the stem protrudes through the stem protector and indicates whether the stem is up or down and whether the valve is open or closed.

The stem is sealed with "V" type packing seals. The packing seals are arranged in an open/closed type packing box. The upper seals are energized at assembly with a bulk packing appropriate for the application. Body pressure energizes the "V" seals and insure contact between the seal, the stem, and the housing.

4. Body/Bonnet

The Model EG valve has a bolted bonnet. There is a dual seal between the body and bonnet. The primary seal is metal to metal with a secondary non-metallic seal.

5. Handwheel Operation

Handwheel operated valves have ball thrust bearings on both sides of the stem nut. The bearings reduce the torque required to operate the valve.

6. Actuation

The valves are normally furnished with handwheel or bevel gear operators, as appropriate for each size. They can readily be adapted to fit a wide range of power operators, if desired. Power operators can be installed in the field or at the manufacturing facility.

7. Pressure Relief Valve

Since an expanding gate valve seals against both the upstream and the downstream seats, fluid trapped in the body cavity can cause excessive pressure. This may be due to a temperature change which can cause thermal expansion of the fluid, or the body may be full of liquid and over-pressured when lubricating the seats.

All M&J valves are equipped with a pressure relief valve fitted to the valve body cavity unless specified otherwise. A typical installation is shown in Figure 2A. As an alternate, the valve can be provided with upstream relief piping which relieves excess body pressure to the upstream side of the valve (Figure 2B). Note: Needle valves must remain open except during testing.

Any pressure relief valve must be tested periodically to ensure reliable functioning. The proper pressure relief settings are shown in Table 1.

TABLE 1

Pressure Class	Operating Pressure (psig)	Shell Test (psig)	Relief Valve Setting (psig)
150	275	425	375
300	720	1,100	820
400	960	1,450	1,060
600	1,440	2,175	1,540
900	2,160	3,250	2,260

Safety Note:

NEVER remove the pressure relief valve.
 NEVER plug the pressure relief valve.
 REPLACE the pressure relief valve if it is leaking, fails to relieve at the proper set pressure, or fails to reseat after test.

A pressure relief valve is an emergency safety device; it is not a substitute for draining the valve body or for taking other common sense safety precautions. The correct relief valves are available through M&J Valve service or sales representatives.

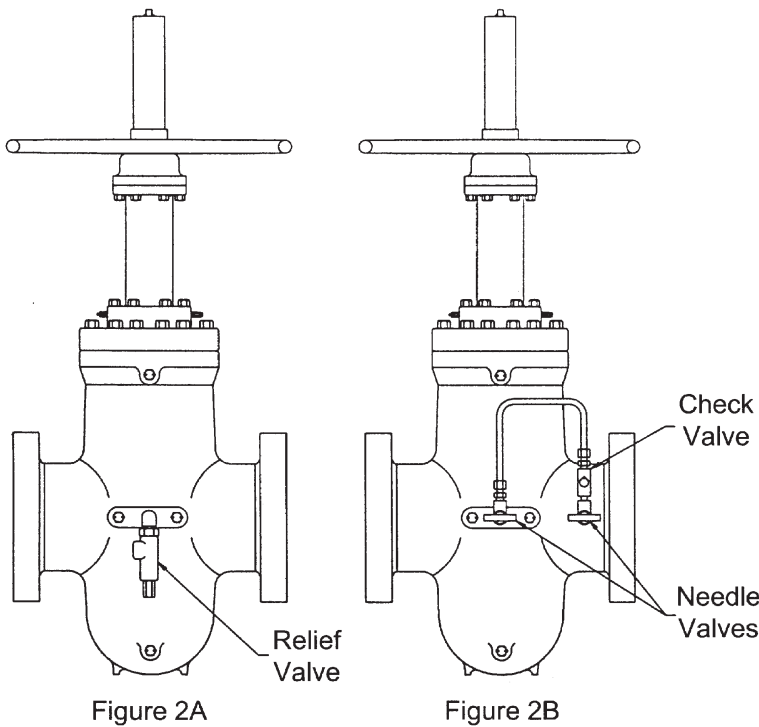

IV. Operation

1. Normal Operation

M&J Valve Expanding Gate Valves are designed for full open to full closed operation by stroking of the stem. Internal stops are provided to position the gate.

1.1 The M&J Valve Expanding Gate Valve (6" and larger) is provided with four (4) combination vent/injection fittings (see Figure 3) in the body. Two fittings are for emergency seat sealant injection (located on the centerline of the pipeline and either side of the gate) and two (2) fittings are provided for venting and draining the body cavity (located on the centerline of the body and near the top and bottom of the body). Valves 4" and smaller are provided with two (2) fittings (one near the top and one near the bottom) for venting, draining, and sealant injection.

NOTE: These combination fittings will not pass large solids when venting. Care should be taken that a false indication of venting does not occur.

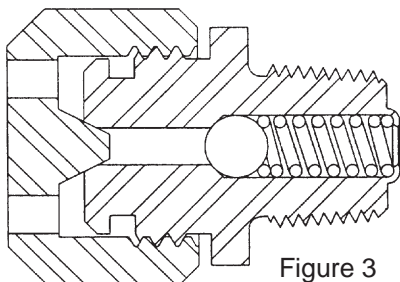

Figure 3

2. Block and Bleed Operation

M&J Valve Expanding Gate Valves provide block and bleed capability in the full closed position. This means that the body cavity pressure can be vented to atmosphere while pressure is maintained in the pipeline.

2.1 Block and Bleed Applications

2.1.1 Verify integrity of both seats.

2.1.2 Allow draining and/or flushing of the valve body cavity.

2.1.3 Absolute prevention of downstream leakage to assure safety of downstream activities.

2.2 Block and Bleed Procedure

2.2.1 Operate valve to the full-closed position.

2.2.2 Remove the upper body combination fitting safety cap (Figure 3). **(Caution: Watch the fitting body to insure that it does not turn while turning the cap. Do not attempt removal of the fitting while the valve is subjected to line pressure. A back-up wrench on the fitting body may be required.)**

2.2.3 Install the pressure releasing tool (see Figure 4) with the stinger retracted. Turn the stinger until it contacts the ball check, then 1/2 turn further to vent the body. (Caution: Care should be taken to insure that the exhaust port on the side of the vent fitting is directed away from personnel.)

2.2.4 Continue venting until body pressure reaches atmospheric pressure. (Note: Length of time required to vent the body will be proportional to the compressibility, the pressure and the size of the valve.)

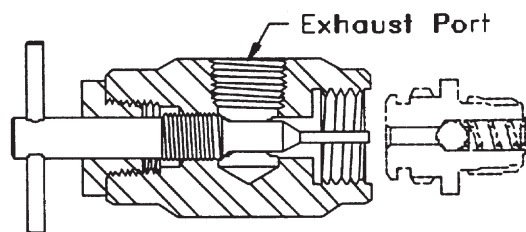

Figure 4

3. Emergency Seat Sealant Injection

3.1 M&J Valve Expanding Gate Valves are designed for long term operation without routine maintenance. Regular injection of sealant is expressly not recommended.

3.2 M&J Valve Expanding Gate Valves have the provision for emergency seat sealant injection. This feature provides a means for emergency seal of a damaged sealing surface using sealant. Injecting sealant in the upstream and downstream seat fittings will provide complete sealing in most downstream and block and bleed leakage situations. Operation of the valve after sealant injection usually requires re-injection of sealant.

3.3 Emergency Sealant Injection Procedure

3.3.1 Remove the combination fitting safety cap (Figure 3). **(Caution: Watch the fitting body to insure that it does not turn while turning the cap. Do not attempt removal of the fitting while the valve is subjected to line pressure. A back-up wrench on the fitting body may be required.)**

3.3.2 Using an appropriate grease gun and sealant, inject sealant into both upstream and downstream sealant fittings while observing leakage. (This may be done using the block and bleed feature above.) Inject sealant only sufficient to eliminate leakage. Partial operation may be required to evenly distribute the sealant. Continued injection is wasteful and contaminates the flow stream.

4. Body Flushing and Draining

4.1 The M&J Valve Expanding Gate Valve is provided with two (2) combination vent/injection fittings in the body cavity. (See Figure 3.)

4.2 Draining Procedure

4.2.1 Draining can be accomplished using the pressure release tool (Figure 4) on the combination fitting in the bottom of the body. Remove the safety cap and install the pressure releasing tool with the stinger retracted. Turn the stinger until it contacts the ball check, then 1/2 turn further to drain the body. **(Caution: Care should be taken to insure that the exhaust port on the side of the vent fitting is directed away from personnel.)**

4.2.2 Draining may also be accomplished by venting the body as in 2.2, above. Then, removing the combination fitting from the bottom of the body. **(Caution: Never remove any fitting without verifying that the fitting is not pressurized.)**

4.3 Flushing Procedure

4.3.1 Flushing the valve body is merely a combination of the Block and Bleed Procedure and the Draining Procedure. The vent fitting can then be removed to allow introduction of the flushing media.

4.4. Potential Hazards of Accumulated Fluids

The accumulation of liquid in the valve can have two major adverse effects. Water may freeze, which can prevent operation of the valve and may cause extreme stress in various components. In addition, should the body fill completely with liquid, an attempt to lubricate the seats can result in a severe increase in valve pressure, sufficient to result in failure and leakage of fluid to the atmosphere.

Solid foreign material may settle out of the flow stream and into the lower section of the valve body. This can prevent the gate/segment from reaching the full downward position and closing fully against the seat. This could result in throttling of the flow which may cause severe erosion and damage to the seats and the gate/segment assembly. Finally, the sediment may eventually plug the openings and prevent draining the valve body.

4.5 Pressure Lock

Pressure lock can occur when body pressure on a two piece gate/mechanical sealing valve exceeds line pressure. This condition may make the valve inoperable or very difficult to operate. To eliminate this condition, vent the valve body pressure as in Section IV, 2.

5. Emergency Stem Seal Plastic Packing Injection

All M&J Valve Expanding Gate Valves are equipped with a packing fitting having a ball check as illustrated in Figure 5. In the event of damage to the stem packing,

which causes a leak, plastic stick packing can be injected into the packing box to increase packing box pressure and eliminate the leakage. A ratchet with a socket, which fits the hex head on the packing fitting stinger, is recommended for this operation.

- 5.1 Remove the packing fitting injection stinger and insert a plastic packing stick into the fitting. **(Caution: Do not remove the stinger if there is continuous leakage through the weep hole of the packing fitting when the stinger is being backed out.)**
- 5.2 Run the stinger all the way in against the seat of the fitting.
- 5.3 Repeat injection of the plastic packing sticks to the extent necessary to stop the stem seal leakage.

NOTE: Excessive packing injection may cause the valve stem to bind and/or decrease the life of the stem seals.

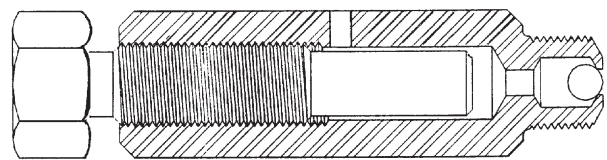

Figure 5

Safety Note:

DO NOT exceed the appropriate packing pressure in Table 2. Excessive packing pressure can cause the valve to be hard to operate and may also shorten the life of the stem seal.

6. Replacing the Injectible Packing

There may be occasions when the packing must be replaced. The valve must be in the fully closed position. Bleed the valve body using the procedure in Section IV, 2.2. Screw the injector screw in all the way against the seat, then remove the injector screw from the fitting ONLY after being certain that the internal ball check is fully seated and is sealing.

Remove the packing plug opposite the packing fitting. Inject packing into the packing box until the old packing is discharged through the packing plug opening. Replace the packing plug, then inject packing until reaching the appropriate pressure shown in Table 2.

Table 2

Valve Pressure Class	Packing box Pressure (psig)
150	1925
300	2600
400	2950
600	3675
900	4750
1500	6900

7. Winterization

Prior to freezing weather, these items should be checked:

- Make sure drain holes in yoke tube are not plugged and that water has not accumulated inside.
- Drain valve body to make certain any accumulated water is removed.
- Check stem protectors to be certain they are not full of water.
- Verify bearings and bearing housings are fully geared.
- Confirm stem and handwheel extensions do not have an accumulation of water.

V. Maintenance

1. Stem Bearings

The valve stem is equipped with roller thrust bearings inside the bearing housing on direct handwheel operated valves, or inside the bevel gear housing on bevel gear operated valves. These bearings provide operating torque reduction and retain the stem.

The housings are equipped with a standard automotive type grease fitting and should be lubricated with a good grade of lithium based bearing grease. Note: Use just enough grease for bearing lubrication.

2. Stem

Grease the stem threads periodically by removing the stem protector with the valve in the open position and applying a good

lithium based bearing grease directly to stem threads. This can be done in tandem with the above stem bearing lubrication. Replace stem protector after lubrication.

3. Yoke Tube

Examine the yoke tube drainholes for grease, condensate, or any foreign matter that may plug the holes.

4. Major Overhaul

Major overhaul procedures are beyond the scope of this manual. Replacement of internal components and seals should be performed by those knowledgeable in the repair and reconditioning of this product. M&J Valve has experienced Service Technicians available worldwide ready to go.

EXPLODED VIEW AND PARTS LIST 2" - 4"

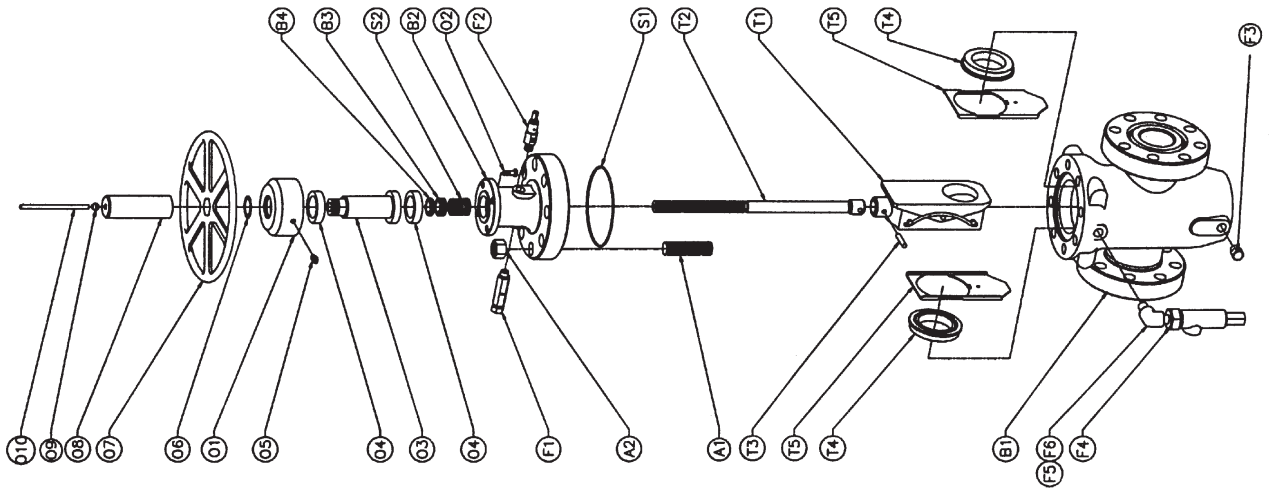

HANDWHEEL OPERATOR

ITEM	DESCRIPTION	QUANTITY
01	Bearing Cap	VAR
02	Capscrews	VAR
03	Stem Nut	1
04	Bearing Set	1
05	Grease Fitting	1
06	O-Ring	1
07	Handwheel	1
08	Stem Protector Assembly	1
09	Indicator Rod	1
010	Rod Wiper	1

ITEM	DESCRIPTION	QUANTITY
A1	Body/Bonnet Studs	VAR
A2	Body/Bonnet Nuts	VAR
B1	Body	1
B2	Bonnet	1
B3	Packing Retainer Nut	1
B4	Packing Retainer Lock Nut	1
F1	Packing Injection Assembly	1
F2	Vent Fitting	1
F3	Body Vent Fitting	1
F4	Relief Valve	1
F5	Pipe Nipple (Drain)	1
F6	Elbow	1
S1	Body/Bonnet Seal	1
S2	Packing Set	1
T1	Gate & Segment Assembly	1
T2	Stem	1
T3	Stem Pin	1
T4	Seat Assembly	2
T5	Seat Skirt	2

EXPLODED VIEW AND PARTS LIST 6" & LARGER

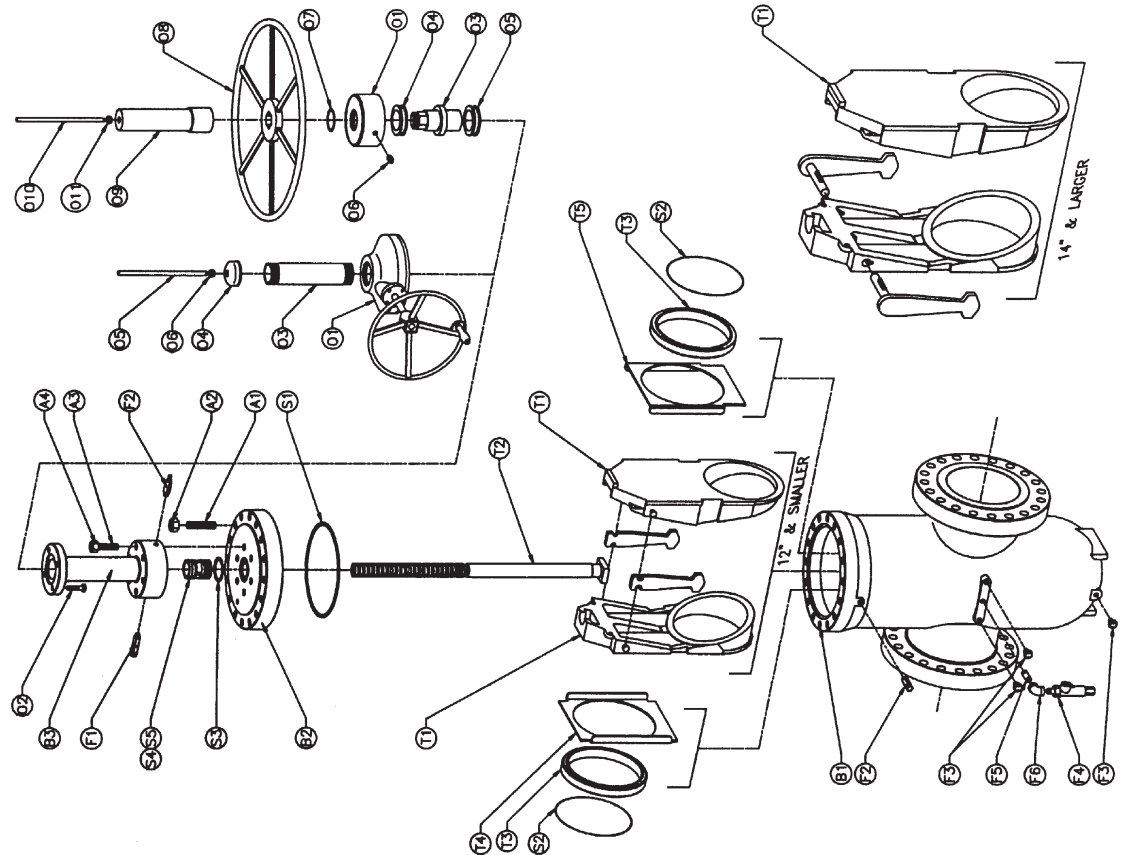

HANDWHEEL OPERATOR

ITEM	DESCRIPTION	QUANTITY
01	Bearing Cap	1
02	Cap screws	VAR
03	Stem Nut	1
04	Upper Bearing	1
05	Lower Bearing	1
06	Grease Fitting	1
07	O-Ring	1
08	Handwheel	1
09	Stem Protector Assembly	1
010	Indicator Rod	1
011	Rod Wiper	1

BEVEL GEAR OPERATOR

ITEM	DESCRIPTION	QUANTITY
01	Bevel Gear Operator	1
02	Cap screws	VAR
03	Stem Protector	1
04	Pipe Cap	1
05	Indicator Rod	1
06	Rod Wiper	1

ITEM	DESCRIPTION	QUANTITY
A1	Body/Bonnet Studs	VAR
A2	Body/Bonnet Nuts	VAR
A3	Yoke Tube/Bonnet Studs	VAR
A4	Yoke Tube/Bonnet Nuts	VAR
B1	Body	1
B2	Bonnet	1
B3	Yoke Tube	1
F1	Packing Injection Assembly	1
F2	Vent Fitting	2
F3	Grease Fitting	3
F4	Relief Valve	1
F5	Nipple (RV)	1
F6	Elbow	1
S1	Body/Bonnet Seal	1
S2	Seat Rear O-Ring	2
S3	Yoke Tube Gasket	1
S4	Packing Set	1
T1	Gate & Segment Assembly	1
T2	Stem	1
T3	Seat Assembly	2
T4	Gate Skirt	1
T5	Seat Skirt	1

Notes



Your local contact:



SPX Flow Control
19191 Hempstead Hwy
Houston, TX 77065
Phone: (800) 231-3690 Fax: (281) 807-2829
E-mail: mjvalve@spx.com

For more information about our worldwide locations, approvals, certifications, and local representatives, please visit www.spxfc.com.

SPX Corporation reserves the right to incorporate our latest design and material changes without notice or obligation.

Design features, materials of construction and dimensional data, as described in this bulletin, are provided for your information only and should not be relied upon unless confirmed in writing.